

EXPERIMENTAL RESULTS ON SELECTION OF THE CO-LASER RADIATION LINES THAT ARE ABSORBED BY THE ATMOSPHERE

V.V. Valuev, V.V. Morozov, O.A. Snitko, A.A. Vaselenok, V.A. Gurashvili,
V.N. Kuz'min, N.E. Sarkarov, and N.G. Turkin

*Scientific Production Center "Sistema," Moscow
TRINITI, Troitsk, Moscow Region
Received August 26, 1998*

Based on comparative analysis of the results on the CO laser emission spectra obtained using two versions of the optical arrangement: an-oscillator with an unstable resonator and the "master oscillator – amplifier" scheme we show in this paper that a portion of the master oscillator resonator that involves the atmosphere can serve as an efficient selector of the CO-laser lines that are absorbed by the atmosphere.

1. INTRODUCTION

The electric-discharge CO lasers have several advantages as compared to other high-power technological lasers. Among those there are higher efficiency, up to 40%, compactness, capability of using overtones for its operation. However, this type of lasers is not widely used because of a significant molecular absorption of the CO-laser radiation in the atmosphere. Using such lasers requires creation of an expensive system for drying the air and for blowing it through across a beam propagation path.

The study of optical characteristics of the active medium of an electro-ionization CO laser¹ has led us to the conclusion that use of the "master oscillator – amplifier" (MO–A) optical arrangement of the laser is most efficient method to decrease the output beam divergence. Besides, it becomes possible to improve the emission "quality" by making the laser to operate on the rotational-vibrational lines that are only weakly absorbed in the atmosphere. To achieve the latter task, one may use a long resonator of the master oscillator providing for a single-mode operation, whose main part is located in the atmosphere outside the gas-discharge chamber (GDC), if the following condition is satisfied:

$$\beta_{\text{atm}} \leq [(\sqrt{\alpha_0 \sigma_0} - \sigma_0)L_{\text{a.m.}} - 1/2 \ln(1/R)]/L_{\text{atm}}, \quad (1)$$

where β_{atm} is the molecular absorption coefficient of the atmosphere; α_0 is the non-saturated amplification factor of the active medium; σ_0 is the non-selective loss in the active medium; $L_{\text{a.m.}}$ is the length of the active medium; L_{atm} is the length of the atmospheric section in the MO resonator; R is the reflection factor of the output mirror of the MO resonator.

As seen from Eq. (1), the proper choice of R and L_{atm} can allow CO laser operation at the lines that are

weakly absorbed in the atmosphere, considering the cascade mode of the CO-laser operation. This is possible, because the lines, at which the molecular absorption is low (close to that by aerosol), exist at all transitions in the CO-lasing bands.

2. EXPERIMENTAL TECHNIQUES AND MATERIALS

In our studies we have used a subsonic fast-blown electric-discharge laser. The working mixture was CO:N₂ = 1:9 at a pressure of 100 Torr and temperature of 100°K at the GDC inlet. The working mixture was pumped by a non-self-maintained discharge. The laser cavity coincided with the gas-discharge chamber.

In the "oscillator" optical arrangement we used a confocal unstable resonator with a corner reflector at the center. The magnification factor of the resonator optics equaled 2. The active medium inside the resonator of the experimental setup consisted, in fact, of two amplification areas of equal length located one after another along the gas flow.

In the MO–A optical arrangement both the master oscillator and a two-pass amplifier have been located in one GDC (Fig. 1). The master oscillator used a stable resonator. Its parameters are as follows: $L = 9.87$ m, $L_{\text{a.m.}} = 2$ m, $L_{\text{atm}} = 6.87$ m, the radius of curvature of the totally reflecting mirror is $R_1 = 43.3$ m; the flat output mirror has the reflectivity $R = 0.5$.

To measure the spectral composition of the output radiation, we have used a grating (echelette with $N = 100$ grooves/mm) spectrometer operated in the second order of diffraction. When analyzing the integral spectrum, it was visualized by quenching the glow of a luminescent screen under the effect of IR radiation. To study the time behavior of separate spectral lines, a cylinder reflector was set in front

of the luminescent screen. The reflector directed beams of radiation at separate spectral lines onto separate elements of the array of pyroelectric detectors. To study the power density distribution of separate spectral lines over the focal spot as function of time, a plane-parallel plate of KRS-6 was mounted in front of the entrance slit of the spectrometer. As the plate rotates, the emitted beam moves along a horizontal direction. The rotation rate of the plate was 5 s^{-1} (the scanning frequency of 10 Hz). Signals from the corresponding elements of the array of pyroelectric detectors were recorded on a phototape of a mirror galvanometer. To increase the spatial resolution over spectral lines, the IR imaging system similar to that described in Ref. 3 was used.

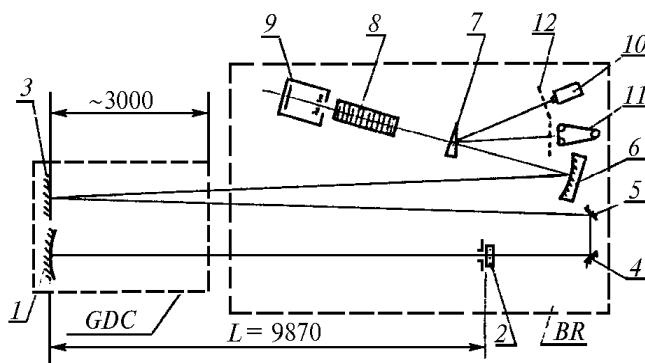

FIG. 1. Optical arrangement "master oscillator - two-pass amplifier" and the instrumentation for recording beam characteristics: the totally reflecting mirror, $R_1 = 43.3 \text{ m}$ (1); the output mirror, $R_2 = \infty$, $R = 0.5 \text{ m}$ (2); the mirror, $R_3 = \infty$ (3); the beam folding mirrors, $R_4 = R_5 = \infty$ (4 and 5); the spherical mirror, $R_6 = 6 \text{ m}$ (6); the optical wedge, $\sigma = 6^\circ$ (7); the caustic meter (8); the spectrum analyzer (PSA) (9); the IMO-2 power meter (10); the tape-transport mechanical scanning, $V = 6000 \text{ mm/s}$ (11); the screens (textolite) (12); the gas discharge chamber (GDC); the measuring unit (BR).

3. RESULTS

The experimental studies of the rotational-vibrational output spectrum of a high-power CO-laser operated using the "oscillator" optical arrangement have revealed the following:

- the lasing occurs at many lines (more than 10 at a time). Among those, four or five most powerful lines yield more than 80% of the total power;
- the recorded lines fall in the range of $5.03\text{--}5.8 \mu\text{m}$;
- within the period of $\sim 0.1 \text{ s}$, the lasing at separate lines achieves a stationary mode both for the total power (Fig. 2) and for the power density distribution in the focal spot (Fig. 3);

- rotational-vibrational emission lines form cascades. Several lasing cascades have been observed simultaneously;

- in the beginning of the lasing process ($t < 0.1 \text{ s}$) low divergency of the beam has been observed at all lines of the CO-laser emission spectrum. After a while the focal spot blurred, and beam divergence increased by three to four times.

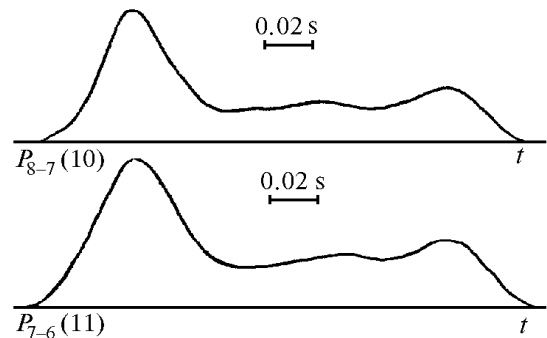

FIG. 2. Time dependence of the CO-laser total emission power at the rotational-vibrational transitions.

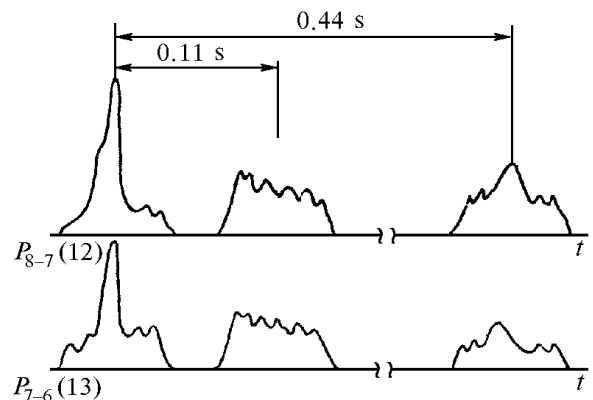

FIG. 3. Time dependence of the spectral power density distribution over the focal spot of the CO laser beam.

Table I presents the experimentally recorded laser emission lines for the two versions of the optical arrangement of the laser and calculated values of the molecular absorption coefficient of the atmosphere at these wavelengths.²

As seen, the molecular absorption of the atmosphere is strong ($\beta_{\text{atm}} = 10 \text{ cm}^{-1}$) at the spectral lines corresponding to the "oscillator" mode of the laser operation (Table I, the first optical scheme).

At the same time, there are no lines strongly absorbed by the atmosphere among the lines obtained with the use of the MO-A optical arrangement (Table I, the second scheme), and the cascade type of lasing is confirmed. The molecular absorption coefficient for the observed lines is within the range of

$\beta_{\text{atm}} = 0.7 \cdot 10^{-4} - 10^{-5} \text{ cm}^{-1}$. This value well agrees with the estimates by Eq. (1) at $\alpha_0 = 1.3 \cdot 10^{-2} \text{ cm}^{-1}$,

$\sigma_0 = 0.08 \cdot 10^{-2} \text{ cm}^{-1}$, and the above values of the parameters $L_{\text{a.m.}}$, L_{atm} , and R .

$P_{v,v-1}(J)$		K_0 wavenumber, cm^{-1}	λ wavelength, μm	β , $\text{mol}\cdot\text{cm}^{-1}$, winter, $m = 0 \text{ km}$
Band	Line			
First optical scheme				
7-6	$p(12)$	1924.2610	5.1968	0.4557 -02
7-6	$p(13)$	1935.5088	5.1666*	0.2156 -05
8-7	$p(11)$	1917.8765	5.2141	0.2380 -02
8-7	$p(12)$	1913.8755	5.2250*	0.1412 -04
8-7	$p(13)$	1909.8548	5.2360	0.1468 -02
9-8	$p(10)$	1896.1659	5.2738	0.2588 -04
9-8	$p(11)$	1892.2191	5.2847*	0.1423 -04
9-8	$p(12)$	1888.3244	5.2957	0.4825 -04
9-8	$p(13)$	1884.3392	5.3069	0.1198 -03
10-9	$p(10)$	1870.5924	5.3459*	0.1858 -03
10-9	$p(11)$	1866.7512	5.3369	0.2280 -03
Second optical scheme				
6-5	$p(7)$	1985.13	5.03800	0.120 -05
7-6	$p(5)$	1966.89	5.08280	0.598 -04
7-6	$p(6)$	1963.08	5.09409*	0.212 -05
8-7	$p(5)$	1941.00	5.15016*	0.223 -04
9-8	$p(5)$	1915.19	5.22025*	0.485 -04
9-8	$p(9)$	1900.04	5.27912*	0.289 -05
10-9	$p(12)$	1862.83	5.36380	0.121 -04
11-10	$p(11)$	1841.30	5.42507*	0.419 -04
11-10	$p(16)$	1821.61	5.49104	0.277 -04
12-11	$p(5)$	1838.24	5.43876	0.336 -04
12-11	$p(10)$	1819.73	5.49104	0.101 -04
12-11	$p(11)$	1815.93	5.51215	0.170 -04
13-12	$p(9)$	1798.15	5.56121	0.950 -04
14-13	$p(11)$	1765.46	5.64936	0.748 -04
16-15	$p(8)$	1726.19	5.79140*	0.640 -04

* Starred are the most distinct lines.

It should be noted that the power density level about $3 \cdot 10^3 \text{ W/cm}^2$ is not lower than in the "oscillator" mode of operation, while the beam divergence has decreased by five times.

4. CONCLUSION

The use of the "master oscillator - amplifier" optical arrangement in a high-power CO-laser makes it possible an efficient selection out of the laser emission lines that are absorbed by the atmosphere. For this purpose, a "long" stable resonator with its largest part being outside the gas-discharge chamber in the ambient atmosphere should be used in the master oscillator.

Under such conditions, the lasing has been obtained at the rotational-vibrational transitions, for

which the molecular absorption coefficient is 10^{-4} – 10^{-5} cm^{-1} . This result allows the field of CO-laser application to be significantly widened.

ACKNOWLEDGMENTS

In conclusion, the authors would like to express their gratitude to A.B. Tikhomirov and V.V. Chernavkin for their help and fruitful discussions.

REFERENCES

1. V.V. Valuev, V.N. Merkushenkov, V.V. Morozov, O.A. Snitko, A.A. Vaselenok, and V.V. Serov, *Izv. Akad. Nauk Ros. Fed., Fiz.* **59(12)**, 160–161 (1995).

2. V.N. Dolina, S.V. Ivanov, I.B. Kovsh, A.I. Kucherov, N.K. Makashov, B.A. Pen'kov, B.M. Urin, and A.V. Shustov, *Kvant. Elektron.* **23**, No. 6, 521–526 (1996).

3. V.V. Morozov, A.J. Petrenko, V.V. Reino, and R.Sh. Tsvyk, *Atmos. Oceanic Opt.* **9**, No. 9, 589–592 (1993).