

## AN X-Y PIEZOCERAMIC OPTICAL DEFLECTOR WITH THE CONTROL BLOCK

L.V. Antoshkin

*Institute of Atmospheric Optics,  
Siberian Branch of the Russian Academy of Sciences, Tomsk  
Received September 15, 1992*

*The paper presents a description of piezoceramic deflectors for optical follow-up systems operating in a turbulent atmosphere and of a high-voltage control block for the deflectors. The sensitivity of a deflector to angular deviations is  $1.43 \cdot 10^{-6}$  rad/V<sup>-1</sup> and the mechanical resonance frequency is about 1.4 kHz. An efficient high-voltage amplifier is constructed of disconnectable current generators. The output voltage is  $\pm 300$  V, the frequency transmission band is 0 to 2 kHz at the load capacity of 0.1  $\mu$ F.*

The accuracy of optical follow-up systems operating in a turbulent atmosphere is to a great degree determined by the efficiency of correction of the laser beam position in space. Thus the development of adaptive laser reference systems and navigation systems operating under regular and random refraction requires the dynamic range of the optical-beam angular position corrector to be further increased, its maximum speed to be enhanced, and its overall size and energy consumption to be simultaneously reduced.

These requirements are best met by optical deflectors with a piezoceramic drive.<sup>1,2</sup>

The paper describes reflecting piezoceramic mechanical end-type deflectors.

A single-coordinate deflector is depicted in Fig. 1a. A mirror reflector 1 is attached to a rocker 2 with a gluing material. The rocker with its runners rests on piezoceramic elements 3 mounted on an insulating

spacer 4 and on a relatively heavy base 6. The entire mechanical joint of the deflector is carried out through a steel string 5 fixed with one end to the rocker and with the other one to the screw 8. The string is stretched by rotating a fixing nut 7. PZ Piezostacks 15 mm in diameter and 4 mm thick cut into 4×4 mm bars are used as piezoceramic elements. The piezoceramic elements are mounted onto the insulators so that the vectors of their polarization are directed in the opposite directions. The circuitry of the piezoelements connections is given in Fig. 1b. Their total electric capacity does not exceed  $\approx 20$  nF for such a connection scheme.

The sensitivity of the deflector to angular deviations is  $1.43 \cdot 10^{-6}$  rad/V. The mechanical resonance frequency of the single-coordinate deflector is between 1.4 and 1.9 kHz and depends on the extent of the string stretching. The aperture diameter is 23 mm.

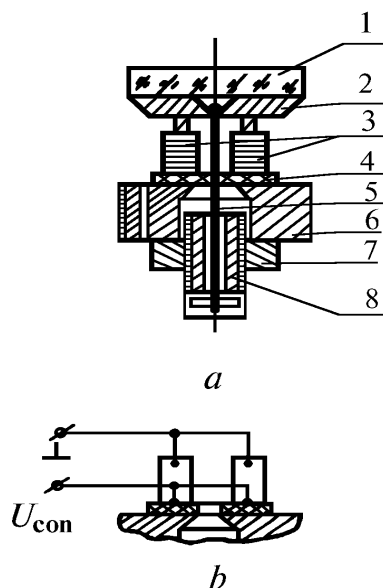

FIG. 1. A single-coordinate deflector (a) and a connection circuitry for piezoelements (b).

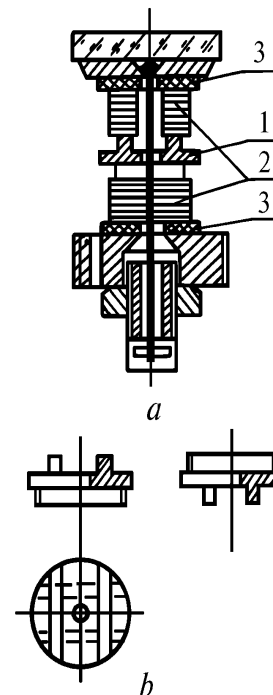

FIG. 2. A X-Y deflector (a) and a rocker device (b).

A thread connection of the base 6 makes it possible to fix it at any frame thus creating X–Y deflectors with mutually crossed axes of their rotation. The foregoing principle has been further developed in the X–Y deflector represented in Fig. 2. In this deflector the rocker 1 is positioned between the lower and upper piezostacks 2 and the insulators 3. Mutual position of the rocker runners accounts for scanning along the two perpendicular directions (Fig. 2b). The sensitivity of the X–Y deflector to angular deviations is  $1.43 \cdot 10^{-6}$  rad/V. The mechanical resonance frequency  $f_r$  is 1.3 kHz. The control systems for voltage of hundred volts are needed to control the optical deflectors with piezoceramic elements. The used high-voltage amplifiers based on d.c. amplifiers with traditional circuits have significant disadvantages: low efficiency, high power to be scattered on output transistors. This brings up a need for radiators of a large area and high-power supplies, all these disadvantages

result in significant increase of the device overall size that requires a search for new designs.

The most promising direction in constructing high-voltage amplifiers operating with a capacitive load is the use of the key methods of amplification.<sup>3,4</sup> The described control block for the piezoceramic unit is a key bipolar-signal amplifier with an adaptive relay pulse-duration modulation (PDM). In this design there is no a sawtooth-voltage generator which is typical of PDM amplifiers. This improves the precision characteristics of the device.

The block diagram of the control unit is depicted in Fig. 3. The output stage with a piezoceramic deflector as a load is composed of two current generators connected in series and triggered with a mismatching circuit. High-voltage transistors operating in a linear regime are employed as output ones that essentially reduces their switching time.<sup>5</sup>

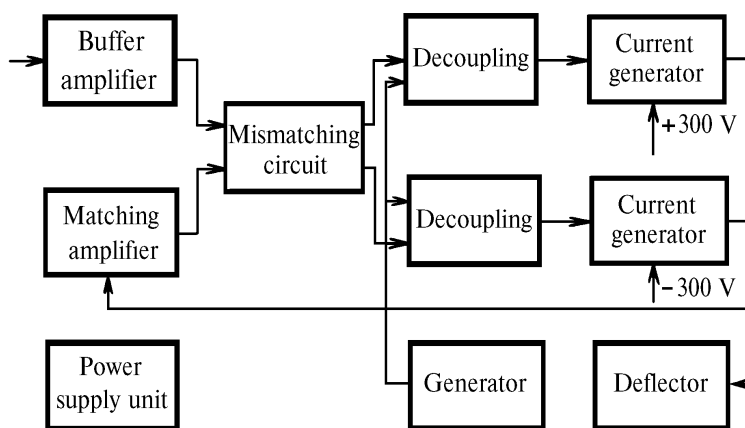

FIG. 3. Block diagram of a control unit for a piezoceramic deflector.

The voltage from the deflector through the divider is supplied to the input of the matching amplifier with high input resistance. A buffer amplifier makes it possible to control the amplification coefficient of the control block and change the sign of the output signal. The signals from the buffer and matching amplifiers are analyzed by the mismatching circuitry (with an insensitivity zone) which depending on a sign of mismatching switches on the current generator with a positive or negative signs. Decoupling between the principal circuitry and high-voltage output stage is accomplished with the help of high-frequency transformers at 5 MHz frequency. The alternating voltage obtained from the secondary cover of the decoupling transformer is detected and serves for prescribing the bias voltage for KT828 output transistors. The output transistors used as switched-off current generators with a short switching time and the comparators with an insensitivity zone allowed one to avoid steady leakage currents and to obtain a good signal-to-noise ratio with insignificant narrowing of the bandwidth. Total value of the current passed through the output transistors is in fact determined only by the reactive impedance of the piezoceramic deflector at the frequency of input signal. The circuitry is fault proof at the output. The maximum amplitude of the output signal is  $\pm 300$  V. The bandwidth for undistorted signal with the maximum amplitude is up to 2 kHz on a load capacitance of 0.1  $\mu$ F.

The dynamic range of the output signal is 66 dB at the signal-to-noise ratio of about 10. The maximum amplification coefficient is  $\pm 60$  and the volume of a single amplifier is 0.4 dm<sup>3</sup>.

Operation of the control units showed that they provide the output voltages higher than  $\pm 600$  V with simple substitution of input transistors by the higher-voltage ones without additional modifications of the circuitry.

Thus the aforementioned devices can be used in creating follow-up optical and angular positioning systems.

The author is indebted to N.N. Botygina, O.N. Emaleev, and S.F. Potanin for their help in testing the described devices.

## REFERENCES

1. L.V. Antoshkin, O.N. Emaleev, and V.P. Lukin, *Prib. Tekh. Eksp.* **5**, 211 (1988).
2. A.A. Kuz'minskii and V.I. Shmal'gauzen, *Prib. Tekh. Eksp.* **5**, 207 (1985).
3. O.A. Kossov, *Transistor Power Amplifiers in a Switching Regime* (Energiya, Moscow, 1971).
4. V.M. Kibakin, *Foundations of Key Methods of Amplification* (Energiya, Moscow, 1980).
5. V.A. Golovatskii, *Transistor Pulsed Amplifiers and Constant Voltage Stabilizers* (Sov. Radio, Moscow, 1974).